

AMPLIFIED IMPACT

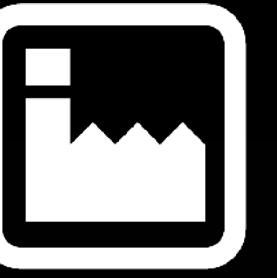

**THE
IMAGINATION
FACTORY**



Industrial Design
Engineering
& Inventive Thinking

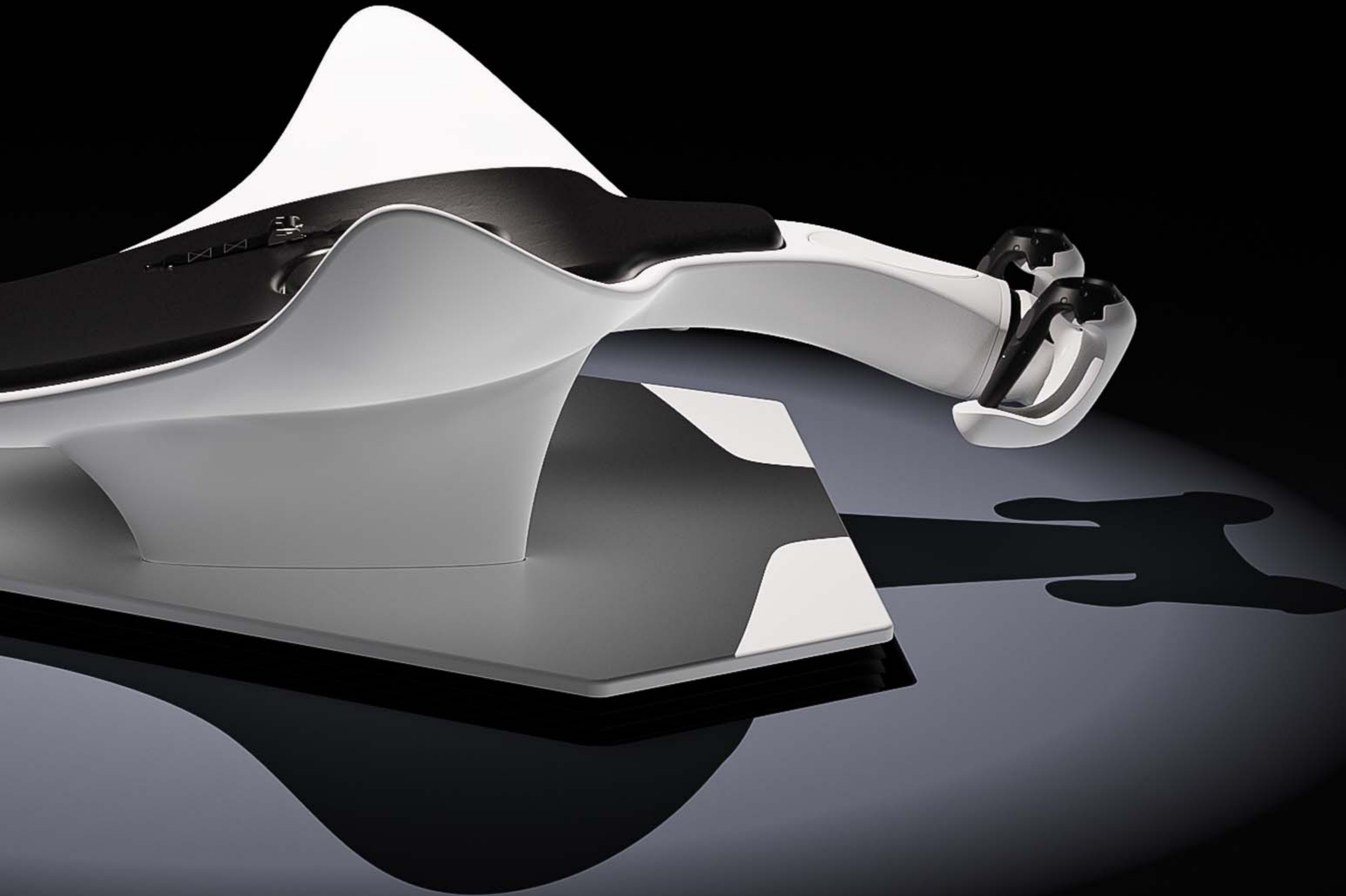

AMPLIFIED IMPACT

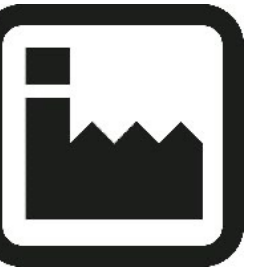

We fuse Strategy
Creativity & Technology
seamlessly together

We do this to
Amplify the Impact
of your products



Mark Hester
Technology Director



Roger Gray
Design Director



Tim Maclean
Engineering Director



Tristram Keech
Creative Director



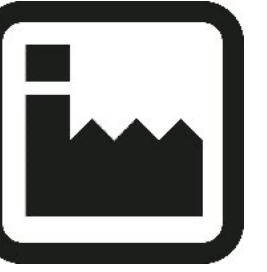

Discover

Scope

Conceive

Detail

Implement

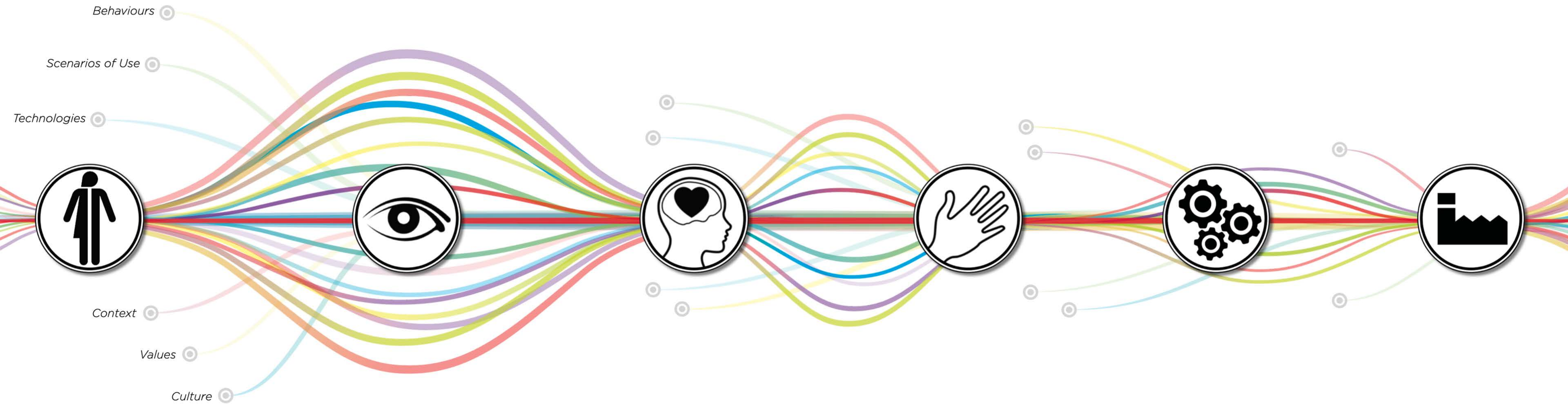

Approach

Human-Centred
Resource-Conscious
Value Creation Strategy
B Corp

Insights

Research
Insight Analysis
Themes & Opportunities
Insight for Innovation

Industrial Design

Initial Ideas
Concept Generation
Creative Direction
Product Visions

Engineering

Mechanical & Electrical
Technology Integration
Prototype & Test
FEA / DFMEA / CFD

Production

Design for Manufacture
Manufacturer Selection
Production Coordination
Quality Inspection

NOTABLE CLIENTS & PROJECTS

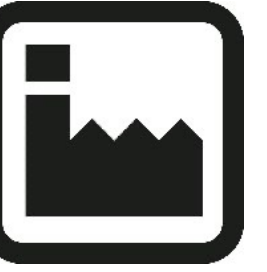

SAMSUNG



GRAVITY



Joseph
Joseph

Manufacturing products from
100% recycled plastic

Non-invasive glucose monitor
for diabetes patients

Vision
ENGINEERING



dyson



SONY

SmartGlasses for people with
Parkinson's disease

Sustainable, customisable
modular smartphone



Shark | NINJA



META



Lufthansa Technik

Food preparation pot for
weaning young children

Holographic heads-up display
for swimmers

Levi's

DIAGEO

easyGym

PLASMA
TRACK

HO/ELOCK

Green energy solution to clear
'leaves on the line'

 **Herman Miller**

speedo

Perrigo

Carlsberg

virgin atlantic 

A range of stereoscopic microscopes
and accessories

Helping break the world record for
human flight

INDUSTRIAL DESIGN

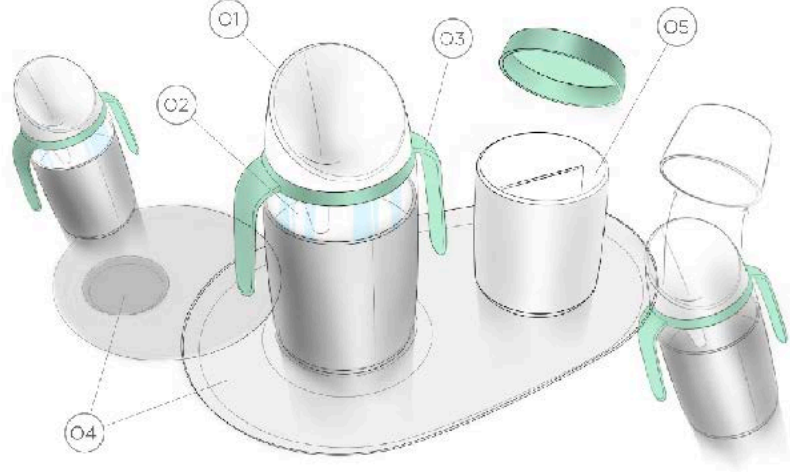
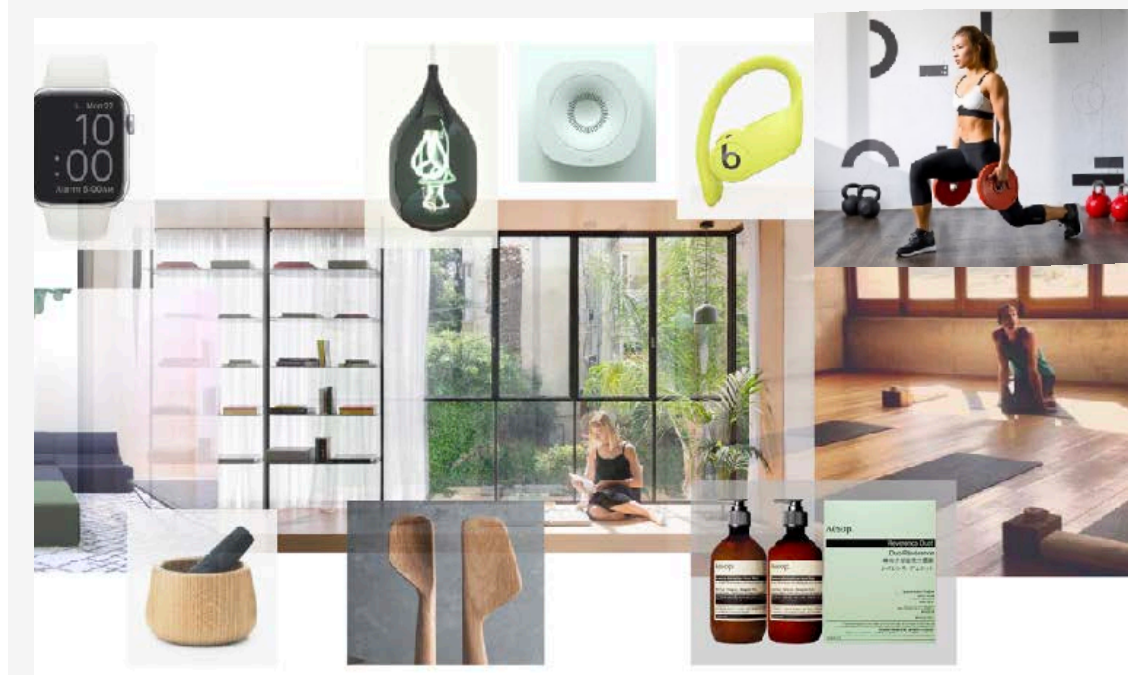
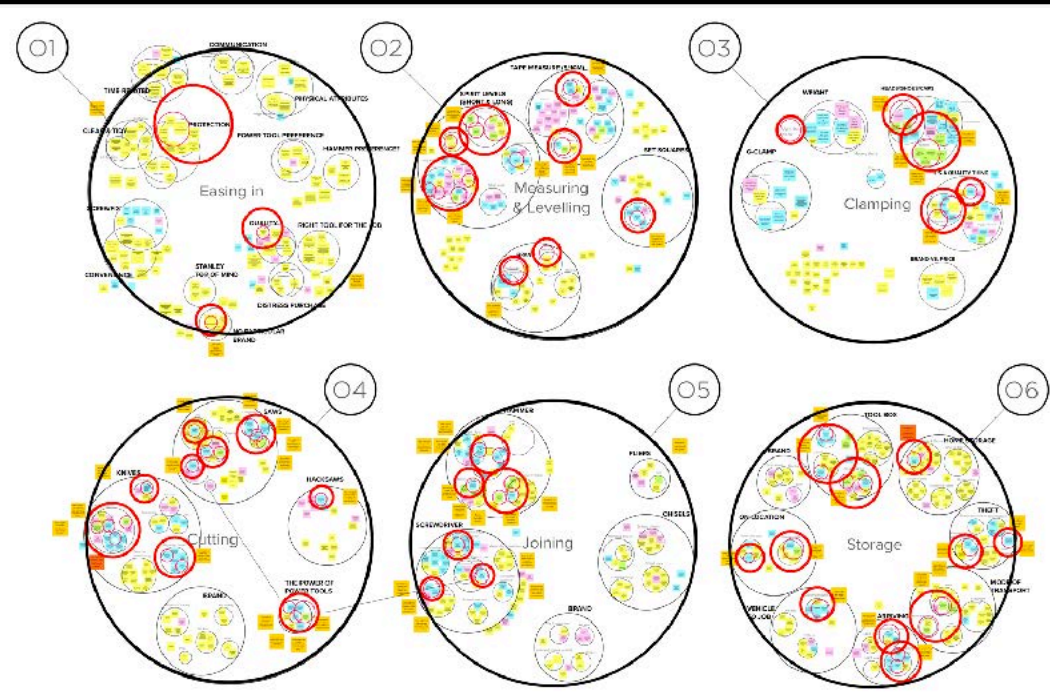
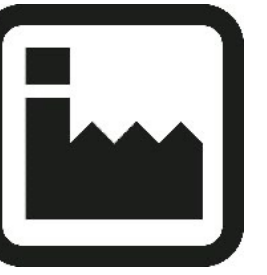

Our ID team not only creates Visual Identities for products it helps our clients identify which products to design



Our Insight for Innovation approach fuels idea and concept generation by revealing what your user audience values most

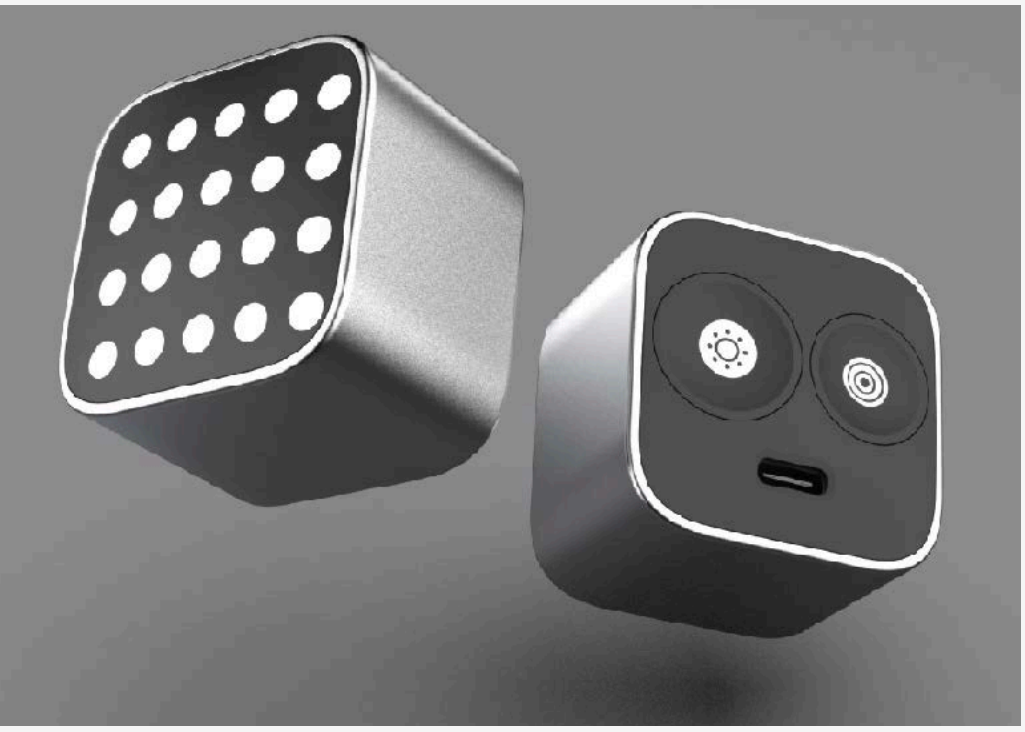

ENGINEERING

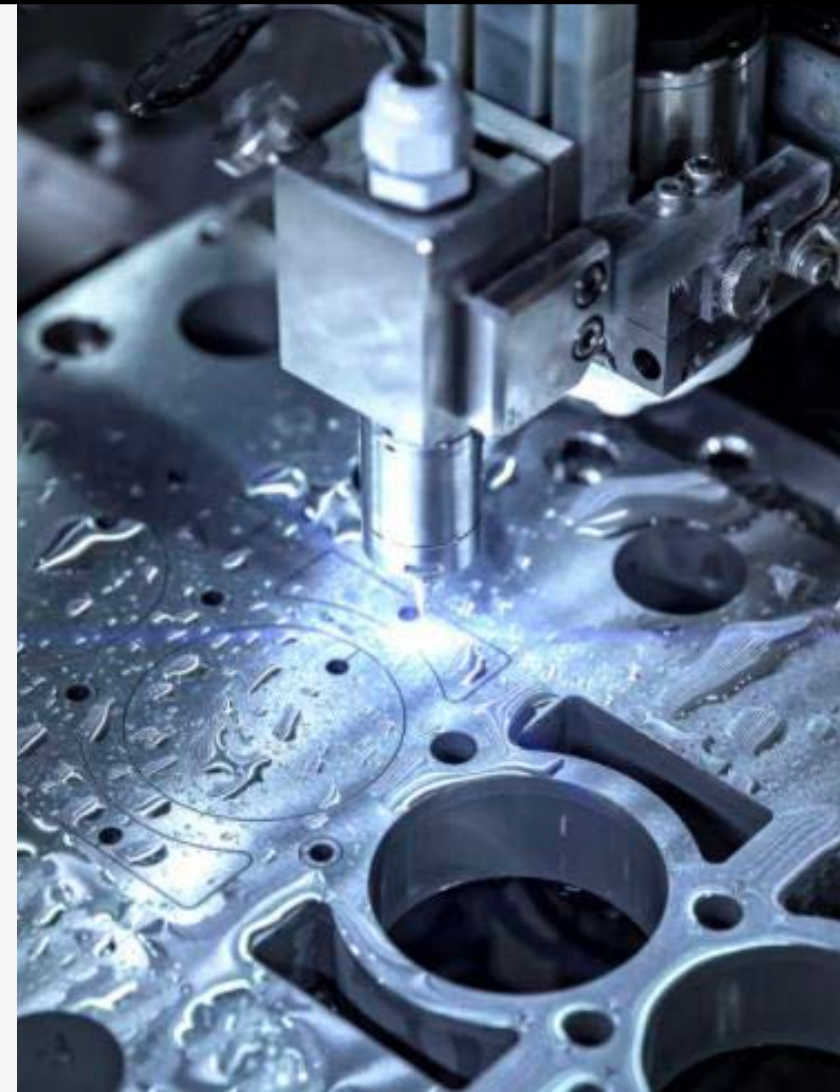
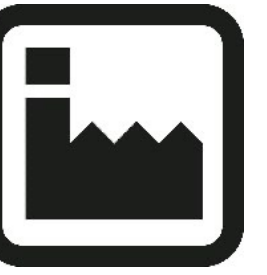

Our engineering team is passionate about resolving difficult technical challenges with rigour and diligence

Our engineers break down problems into fundamentals, focus on the critical operation and then creatively rebuild robust systems to preserve desired performance

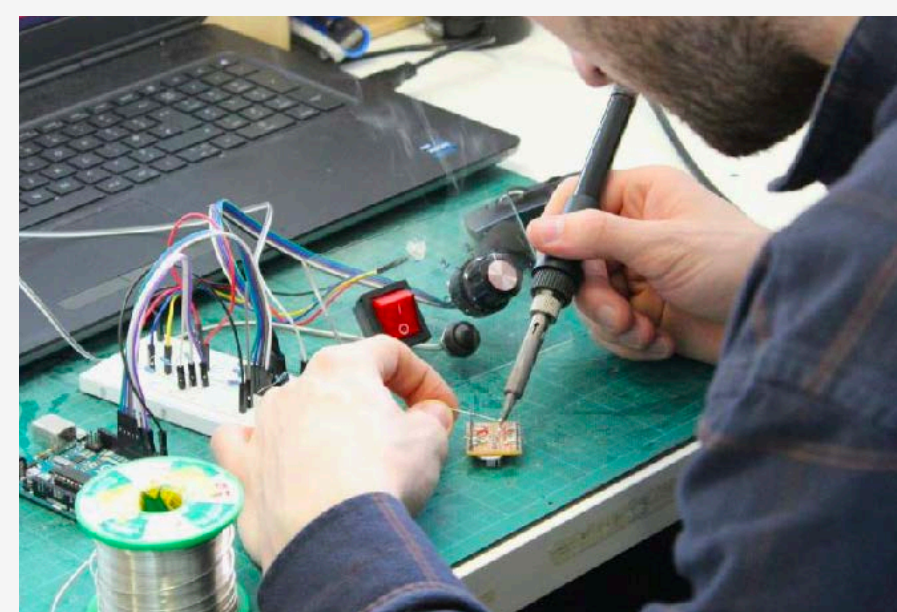

INVENTIVE THINKING

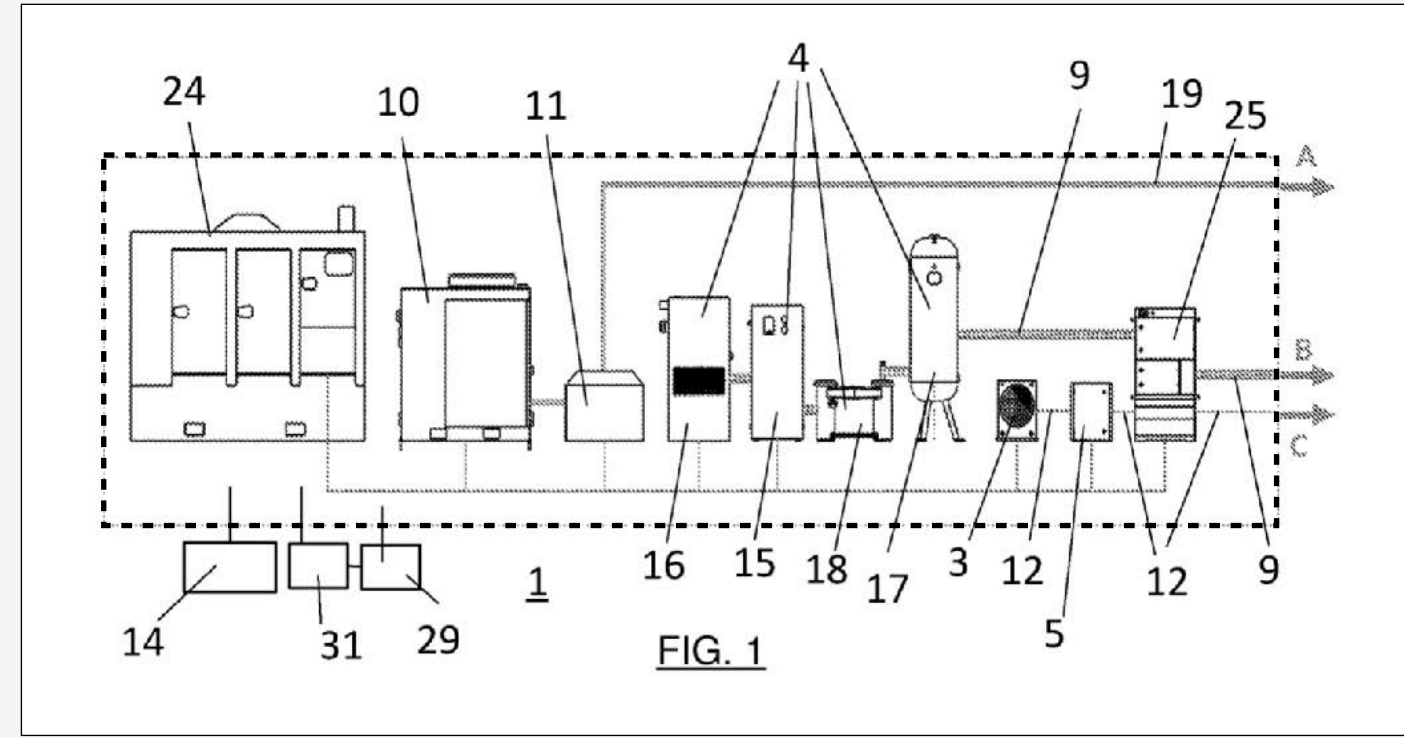
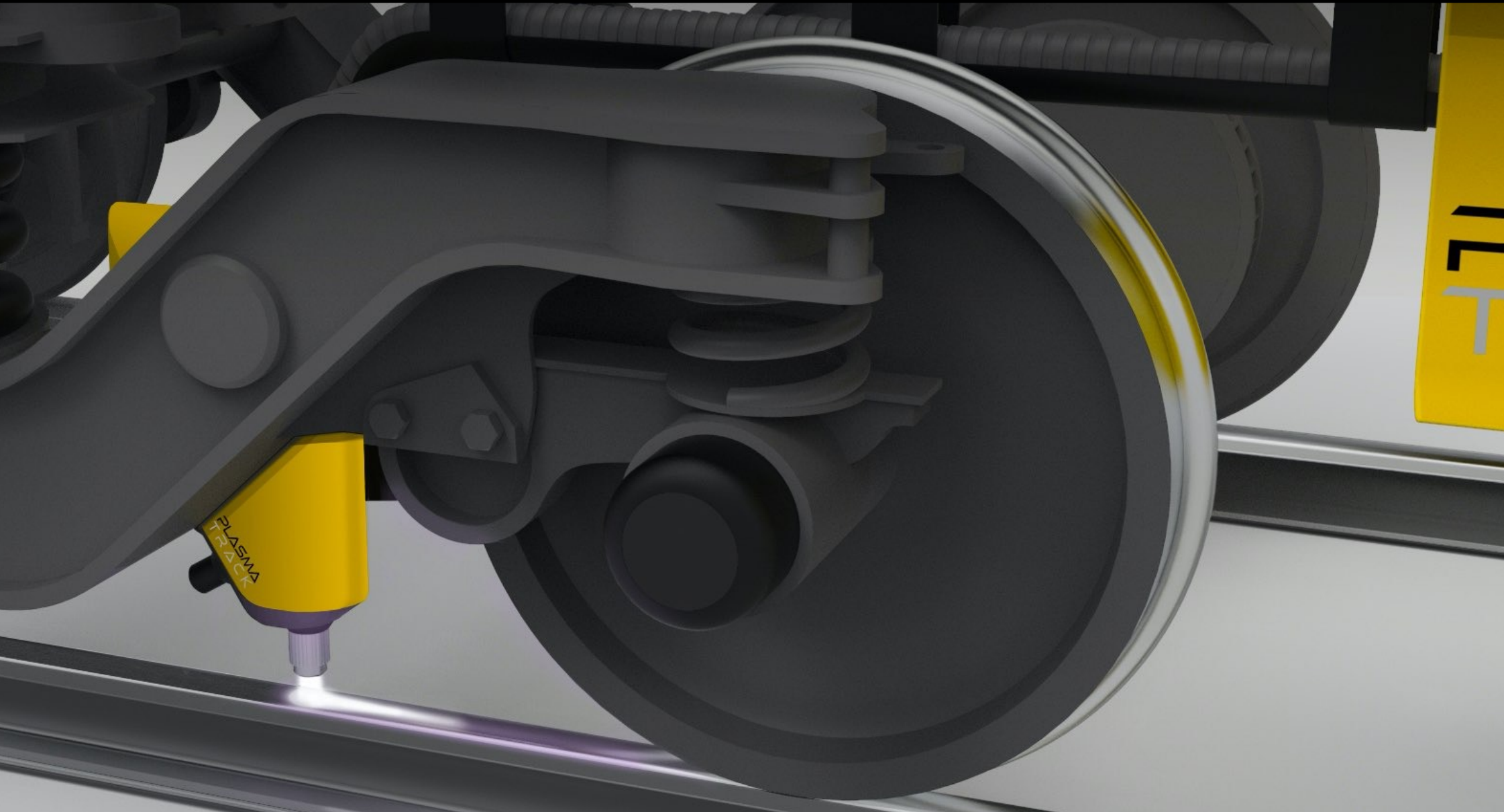
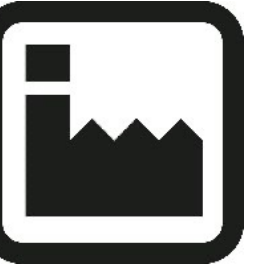

Inventive thinking for clients that require radical innovation for IP generation

We collaborate with global organisations start-ups & grant-funded research projects

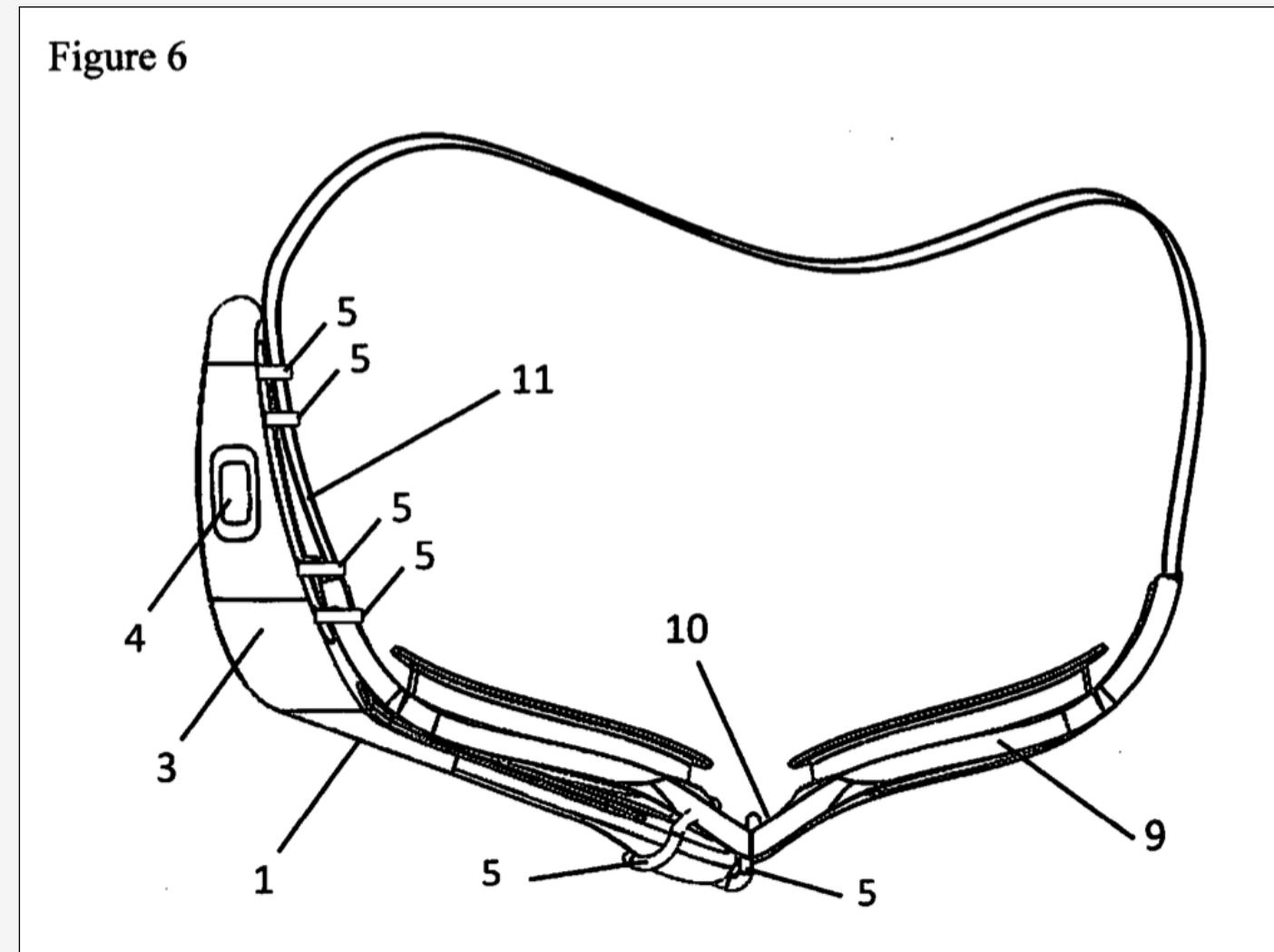

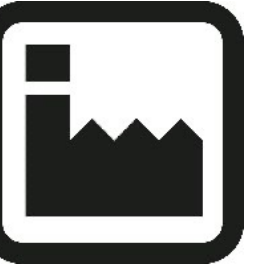

HUMAN-CENTRED INNOVATION

We have adopted a process that integrates a human-centred approach to innovation

The LUMA System helps to de-risk each stage, giving you confidence that your customer audience will love your products as much as you do



VALUE-FOCUSSED STRATEGY

Using various Strategyzer techniques, we help you devise relevant, differentiated product Value Propositions

These will translate the best of your Brand, Design and Quality into innovative possibilities for commercial viability testing

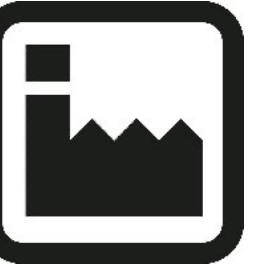

RESOURCE-CONSCIOUS DESIGN

It is said that 80% of a product's environmental impact is decided at the concept stage. This is the driving force behind circular product design

We assist in improving our clients' sustainability strategies as we seek to develop products designed with end of life in mind



THE PolyCE INITIATIVE

Successful circular product design requires an understanding of materials, recycling processes, energy systems and much more. We can help you

Our involvement with the EU-funded PolyCE initiative gives us experience working with manufacturers, polymer scientists, waste collectors and recyclers



PEOPLE + PLANET + PROFIT

The Imagination Factory is a for-profit business that has met a rigorous third-party standard for overall social and environmental performance, legal accountability

We align our interests of with those of wider society, providing positive impact on communities and the environment

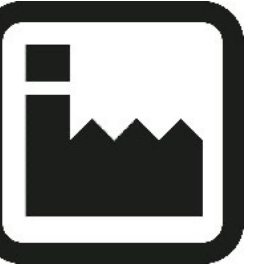

INTELLECTUAL PROPERTY PROTECTION

Venture Proof was established to help innovators protect their original work, be it an idea, an invention, an innovation or business venture

They offer forward-thinking expertise in IP Law, Trademarking, Copywriting and Design Registration



LIFE CYCLE ANALYSIS

Eight Associates help businesses develop strategies and solutions to achieve their sustainability goals and deliver Net Zero.

They provide expertise in sustainable design, environmental measurement, impact reporting and certification.



MANUFACTURING

IntreTech provides access to world-class production expertise, both locally and globally

Using modular micro-factory systems, as well as robotic and automation solutions, our clients can achieve the best combination of cost, speed and quality

Power Road Studios
114 Power Road
London / W4 5PY

imaginationfactory.co.uk



**THE
IMAGINATION
FACTORY**